

COMPLETE THE CABLE PART NUMBER IN THE BOX

T156-

HUB 1 SEE PAGE 2	HUB 2 SEE PAGE 2	STRAND END 1 SEE PAGE 3	SPRING END 1 leave blank for no spring SEE PAGE 4	STRAND END 2 SEE PAGE 3	SPRING END 2 leave blank for no spring SEE PAGE 4	STRAND LENGTH	CONDUIT LENGTH
---------------------	---------------------	----------------------------	---	----------------------------	---	---------------	----------------

*****NOTE*****
When measuring a cable make sure it is laying straight. Bends in a cable can change how far the strand sticks out of each end.

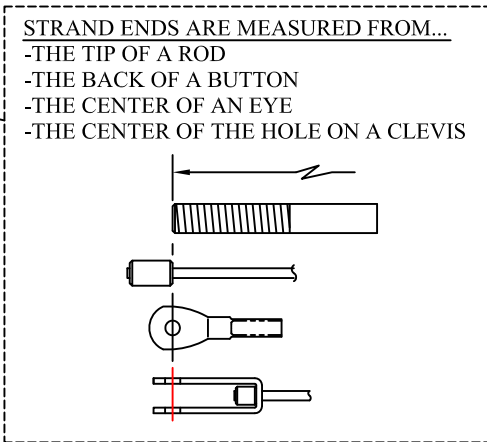
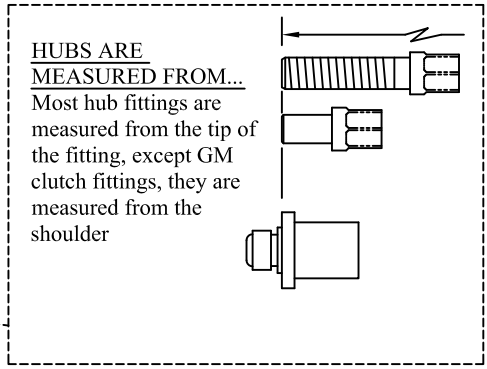

PART NUMBER EXAMPLE

The cable shown here is a... T156- B C 01 u 12 - 61.25 / 52.5

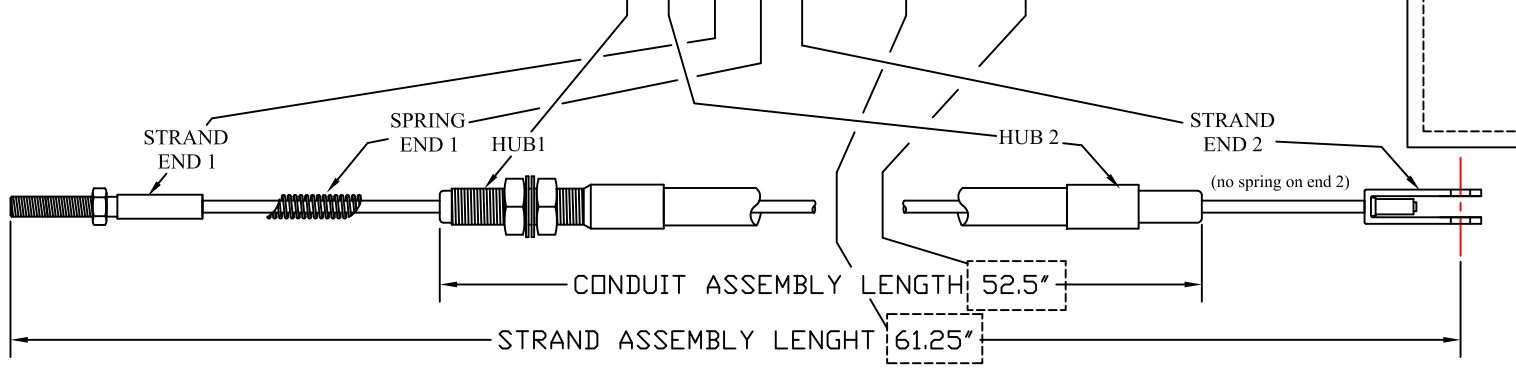

NAME: _____

ADDRESS: _____

PHONE: _____

SIGNATURE: _____

BY SIGNING I APPROVE THE MEASUREMENTS ON THIS DRAWING, AND UNDERSTAND THAT THIS CUSTOM CABLE IS NON-RETURNABLE

6 SERIES HD TENSION CABLE IS RATED FOR 600 lbs PULL LOAD
7" MINIMUM BEND RADIUS

Revisions
Rel-



6019 CR 77 - Millersburg, OH 44654 - (330) 893-0242

6 SERIES HD TENSION CABLE ORDER SHEET

Drawn: JWY	Date: 6/5/2020	Drawing Number	Rev
Sim to:		T156-TENSION CABLE	Rel

Page 1 of 4

PAGE 2 - HD TENSION HUBS

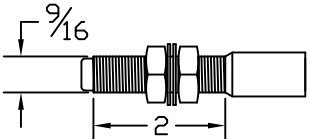
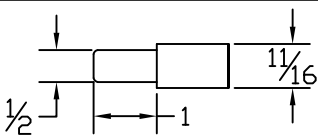
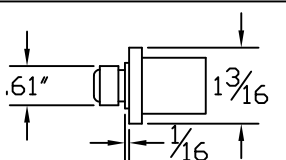
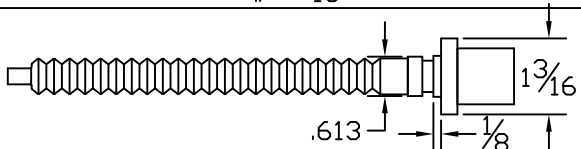
HUB LETTER	DRAWING	DESCRIPTION
B		BULKHEAD HUB 9/16-12 THREAD (INCLUDES 2 JAMB NUTS)
C		CLAMP HUB 1/2" DIA.
M		GM stlye clutch, snap ring hub with internal seal
N		GM stlye clutch, snap ring hub with boot









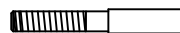

6019 CR 77 - Millersburg, OH 44654 - (330) 893-0242

6 SERIES HD TENSION CABLE ORDER SHEET

Drawn: JWY	Date: 6/5/2020	Drawing Number	Rev
Sim to:	T156-TENSION CABLE	Rel	Page 2 of 4

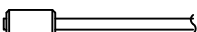
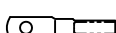
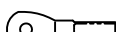
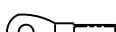
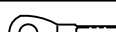
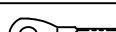
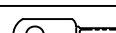
PAGE 3 - HD TENSION STRAND FITTINGS

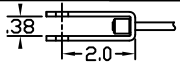
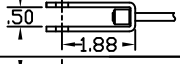
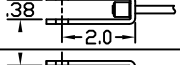
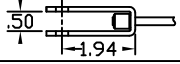
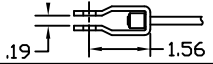
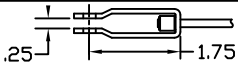
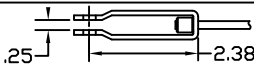
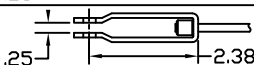
FITTING LETTER	PICTURE	DESCRIPTION
27		ROD 5/16-24, 1" LONG THREAD, 2" LONG
01		ROD 5/16-24, 1-1/2" LONG THREAD, 2-7/8" LONG
02		ROD 5/16-24, 2-1/4" LONG THREAD, 3-5/8" LONG
28		ROD 5/16-24, 3" LONG THREAD, 4" LONG
03		ROD 3/8-24, 1-1/2" LONG THREAD, 2-5/8" LONG
04		ROD 3/8-24, 2-1/2" LONG THREAD, 3-5/8" LONG
29		ROD M10x1.5, 6" LONG THREAD, 7-1/4" LONG
05		BUTTON, FLAT, .31" Dia x .53" LONG
26		SWAGE EYE, 1/4" PIN, 1/2" WIDE, 3/16" THICK
24		SWAGE EYE, 1/4" PIN, 3/4" WIDE, 1/4" THICK
08		SWAGE EYE, 5/16" PIN, 3/4" WIDE, 1/4" THICK
09		SWAGE EYE, 3/8" PIN, 3/4" WIDE, 1/4" THICK
10		SWAGE EYE, 1/2" PIN, 3/4" WIDE, 1/4" THICK
30		EYE, GM CLUTCH, 3/8" PIN (plastic bushing)
12		CLEVIS, 5/16" PIN, 3/8" x 1-5/8"
13		CLEVIS, 5/16" PIN, 3/8" x 2"
14		CLEVIS, 5/16" PIN, 1/2" x 1-7/8"
17		CLEVIS, 3/8" PIN, 3/8" x 2"
18		CLEVIS, 3/8" PIN, 1/2" x 1-15/16"
20		CLEVIS, 5/16" PIN, 3/16" x 1-9/16"
21		CLEVIS, 5/16" PIN, 1/4" x 1-3/4"
22		CLEVIS, 5/16" PIN, 1/4" x 2-3/8"
23		CLEVIS, 3/8" PIN, 1/4" x 2-3/8"









6019 CR 77 - Millersburg, OH 44654 - (330) 893-0242

6 SERIES HD TENSION CABLE ORDER SHEET

Drawn: JWY	Date: 6/5/2020	Drawing Number	Rev
Sim to:		T156-TENSION CABLE	Rel
			Page 3 of 4

PAGE 4 - SPRINGS

u		SPRING, 7.75" FREE LENGTH, 2.88" COMPRESSED, 5.3 POUNDS PER INCH
v		SPRING, 10.50" FREE LENGTH, 3.50" COMPRESSED, 5.0 POUNDS PER INCH
w		SPRING, 10.00" FREE LENGTH, 3.50" COMPRESSED, 4.7 POUNDS PER INCH
x		SPRING, 5.00" FREE LENGTH, 1.38" COMPRESSED, 5.5 POUNDS PER INCH
y		SPRING, 5.30" FREE LENGTH, 2.75" COMPRESSED, 11.5 POUNDS PER INCH
z		SPRING, 5.00" FREE LENGTH, 2.25" COMPRESSED, 11.5 POUNDS PER INCH



6019 CR 77 - Millersburg, OH 44654 - (330) 893-0242

6 SERIES HD TENSION CABLE ORDER SHEET

Drawn: JWY	Date: 6/5/2020	Drawing Number	Rev
Sim to:		T156-TENSION CABLE	Rel
			Page 4 of 4